

Drive & Control profile

Event-Driven Motion Control: Flex Profile Offers More Benefits in Machine Motion

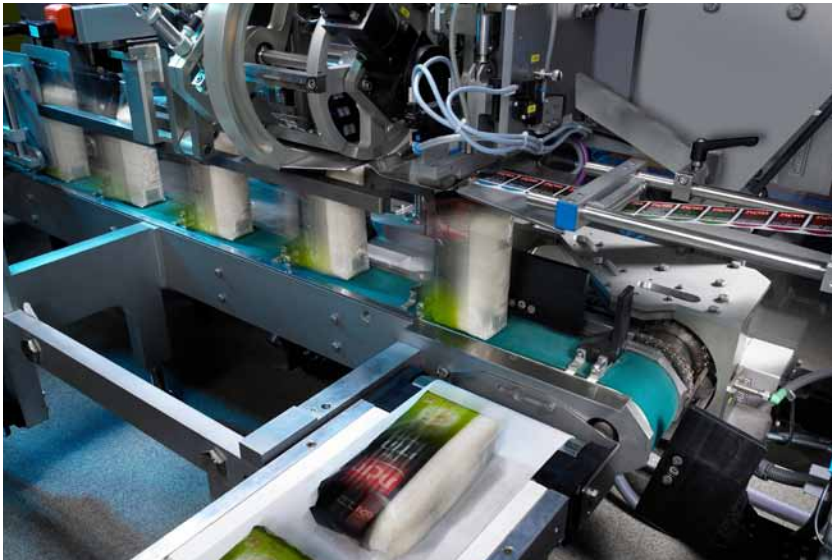

By integrating event-driven strategies into our motion control schemes, automation systems may be optimized beyond what's possible with traditional electronic cams or motion profiles. Until now, such strategies have tended to be limited by point-to-point motions and ad hoc methods. Bosch Rexroth's Flex Profile technology provides a structure under which event-driven strategies may be fully realized.

*By Carl Bostrom
Senior Applications Engineer*

Servo motors have largely replaced mechanical cams as the standard means of meeting the motion demands of the automation industry. The reasons are well-known: Mechanical simplicity and system configurability are the two most common, but improved synchronization, ease of machine

servicing and elimination of wear parts, among other benefits, are often cited as well.

Still, even when not physically present, the influence of mechanical cams may still be felt. Cams continue to shape the way we approach machine-building

Real-world benefits of Flex Profile

- Energy savings: Adaptive control shortens motion trajectories whenever possible, saving energy.
- Reduced wear and tear: Higher-order motion laws minimize jerk and acceleration, leading to longer mechanism and machine life.
- Reduced material waste: Good control schemes and real-time information response tend to provide greater system efficiencies resulting in fewer rejects.
- Higher throughput: Eliminating unnecessary movements leads to higher machine speeds.
- Simplified coding: With a comprehensive programming framework for motion, code is simplified and made more re-usable. Instead of defining motion sequences, decision switches and recovery handling and so on, the programmer simply configures a Flex Profile and runs it. Simplified, reusable code tends to be better tested and proven.

and the way we program our automation systems; we tend to think in terms of “electronic cams” and their associated cam tables. To some extent, this makes sense. Packaging machines, for example, often require repetitive motions and in these cases, the cam paradigm serves us well. However, in many situations, we fail to take full advantage of process information already present in our system. Our machines are *repetitive* when they could be *adaptive*.

Flex Profile is a segment-based cam technology from Bosch Rexroth that can help implement these adaptive strategies. It does so by incorporating event handling directly into the Flex Profile object definition. Also key is the ability to define segments based on synchronization constraints. For example, we may define a segment that prescribes an axis return to a given position at a specified velocity and acceleration once the master axis reaches some threshold, say 360 degrees.

Cam model vs. event-driven model

We compare the traditional, cam-based model to the event-driven model with a common example from the packaging world—the vertical form-fill-sealing machine (VFFS).

Figure 1 describes a dynamic sealing mechanism typical of a VFFS machine. During the sealing operation, the mechanism travels together with the film as it is fed downward. After the sealing operation is completed, the jaws open and the mechanism returns

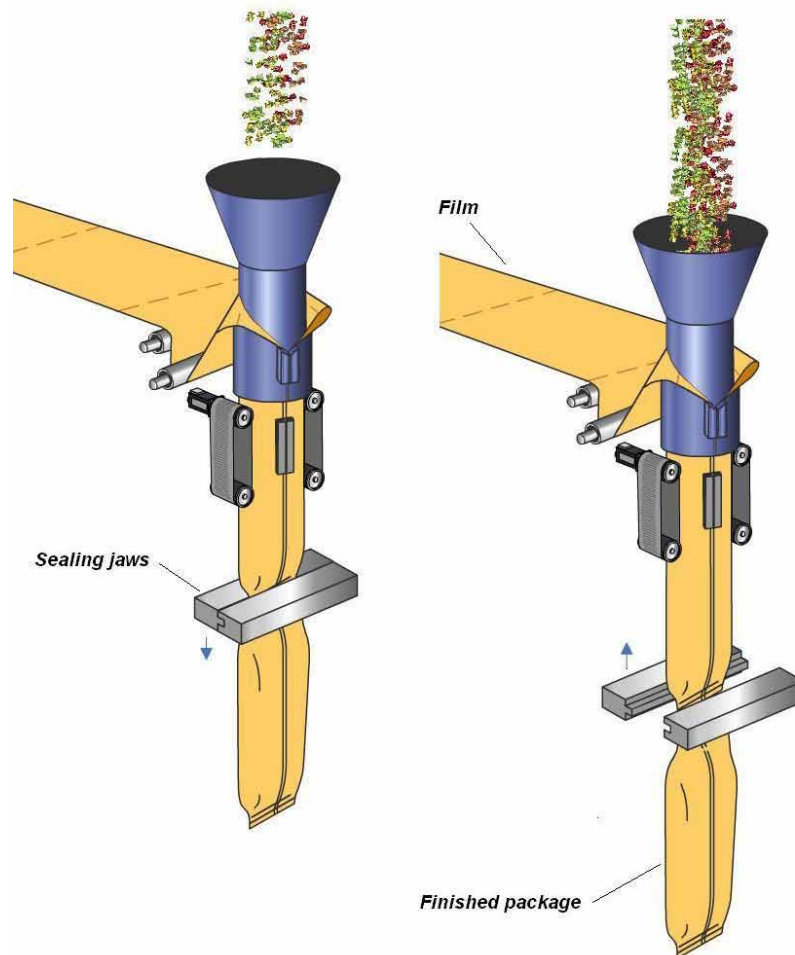

Figure 1. Steps in the production of a vertical form-fill-seal package.

upward to its starting position for the next cycle.

Cam model: Following the cam paradigm, we might approach our programming task by predefining the *x* and *y* motions of the mechanism via cam tables. Here the motions would be defined according to our knowledge or assumptions of the process requirements. For example, as shown in Figure 2, we could predefine a sealing time of 150 ms and define cam profiles based on the current machine speed accordingly.

This method might be acceptable in situations where the sealing process was reasonably consistent. In case of format or process changes (e.g. longer bag length or increased sealing time), cam tables could be recalculated to accommodate the new requirements, but these changes could not be realized during the current machine cycle. At best, the new motions would be loaded into a memory buffer and would be available for activation only in later machine cycles. Also, abrupt changes in film feed speed could result in over-sealing or under-sealing.

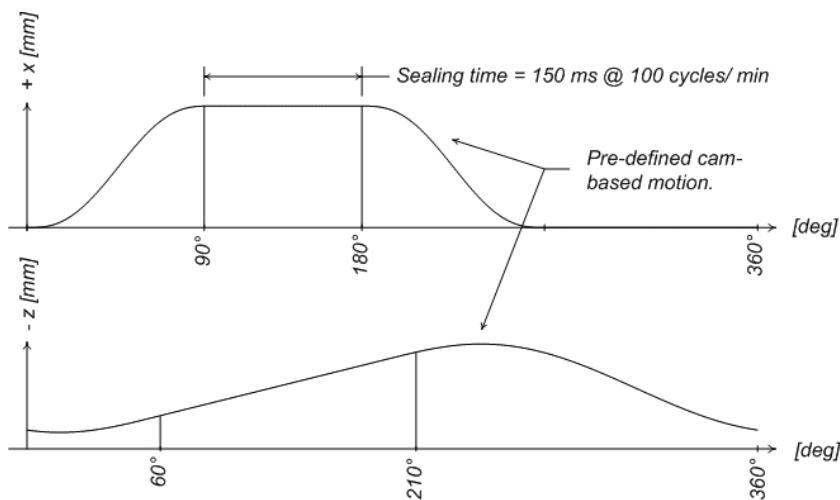

Figure 2. Cam profiles based on an assumed master speed of 100 cycles/minute. In this case, to achieve a sealing time of $t = 150$ ms, sealing is defined to occur between 90 degrees and 180 degrees of the master cycle.

Event-driven model: Suppose instead that our machine could monitor the sealing process, for example by means of a thermocouple mounted to the sealing surface or an external timer, and broadcast when this process was complete. Optimally, we would then immediately open the sealing jaws and return to our start position in preparation for the next cycle. Doing so would minimize total travel, resulting in lower average velocities over the machine cycle at a given machine cycle rate. The general idea is mapped out in Figure 3. Note that such a scheme requires that the motion be defined with a certain amount of flexibility built in. First, we must be able to respond to the external event itself. Additionally, we must be able to compensate *in-process* to the variability implicit in any event-driven scheme. In other words, the motion plan must be able to adjust automatically regardless of when our trigger event comes. Note that the cam approach as described

previously cannot realize this optimization since changes to the cam motions only take effect in later machine cycles.

Bosch Rexroth Flex Profile

Flex Profile provides a comprehensive framework in which to address the demands of the form-fill-seal application described

previously. Each Flex Profile is defined as a collection of segments or steps. These segments are of two types: *Standard*, in which the motion trajectory is pre-specified mathematically, and *Flex*, in which the motion is defined by some goal or restraint. See Figures 4 and 5. In the case of standard steps, the drive is commanded to move a certain distance or *Hub* as the master moves within a defined *Range*. This motion proceeds according to a specified motion law; the motion law generates a trajectory between the specified boundary conditions. Note that the master axis may be a real or virtual axis, or the master may be time-based.

The Flex segments are defined somewhat differently. One still provides a motion law, but rather than defining the trajectory explicitly, one specifies a goal. For example, one might require that the axis, regardless of its current position, reach a certain target once

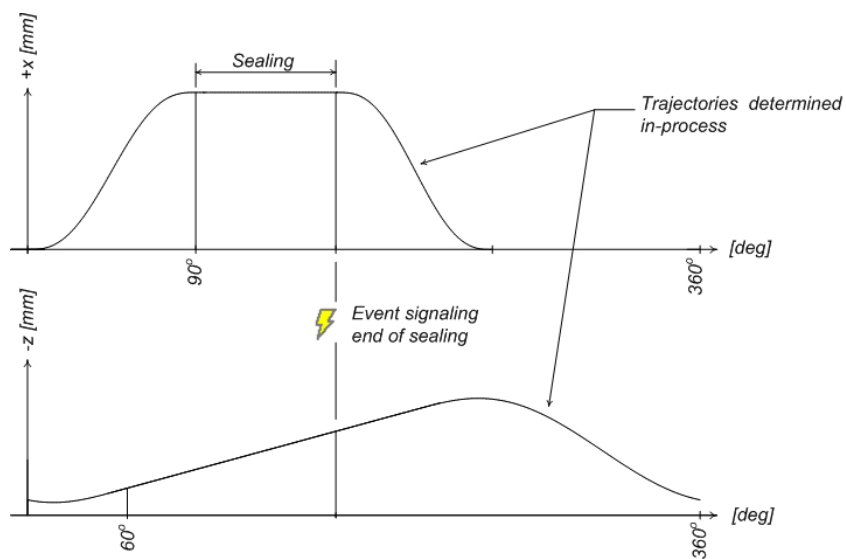

Figure 3. In the event-driven motion model, the sealing bars open as soon as the event occurs and (after some overlap) the bars return to their start position. Note that in this scheme the return trajectory is not predetermined as the event may occur at any time.

the master crosses some specified threshold. Alternately, one might require that the axis reach some position over the next 90 degrees of master travel. The motion trajectory itself is not specified, only the final outcome.

Applying Flex Profile to VFFS packaging equipment

Returning to the VFFS example, Figure 6 describes the horizontal motion of the sealing mechanism as a function of the film position. Because we must only come into contact with the film once the speeds of the mechanism (in the vertical direction) and the film match, the first segment is defined as a synchronous segment. The next segment is defined as a time-based step whose length is given as the maximum possible seal time. In our case the end of the sealing process will be triggered by an external timer or some process monitor: The maximum seal time is used here to define the default behavior of the Flex Profile. The sealing bars then open, again according to a time-based master, which is to say at a defined rate of speed. The duration of the final step, in which the sealing bars are fully open, is calculated internally by the system. This is the so-called “Flex Step,” during which we transition from a time-base step back to being fully synchronized with the real or virtual master.

Figure 7 describes the vertical motion of the sealing mechanism, again as a function of the film position. Here all Flex Profile segments are synchronous with the

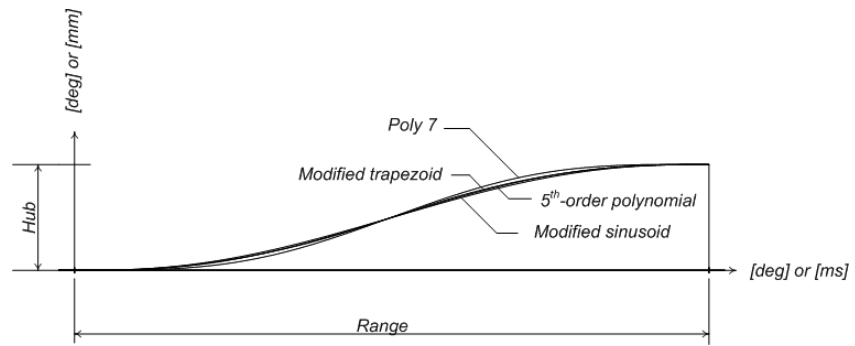

Figure 4. Standard segment, various motion laws shown. Standard segments may be synchronous or time-based. Synchronous and time-based steps, together with the Flex segments defined below, may be combined to form a final Flex Profile.

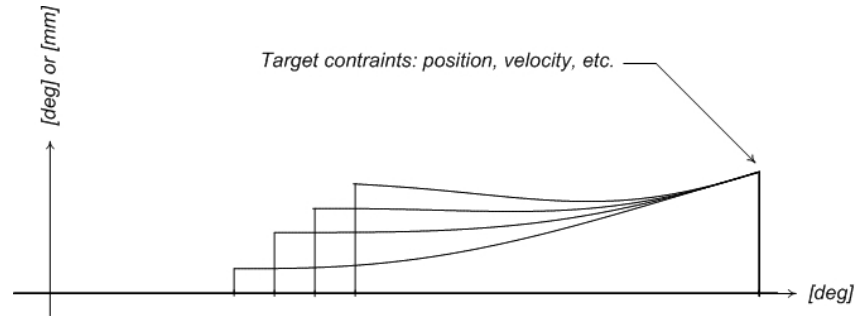

Figure 5. Flex segments are defined by the target constraints. The final trajectory is determined automatically at run-time. Trajectories for various initial conditions are shown.

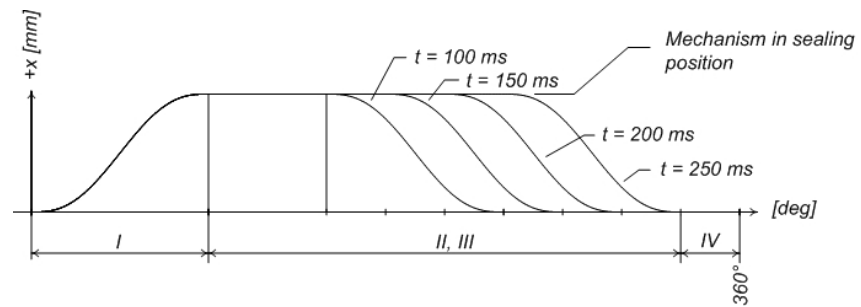

Figure 6. Family of curves defined by event-driven Flex Profile, x-axis. Sealing times of $t = 100$ ms, 150 ms, 200 ms and 250 ms (default) are shown.

master. Step I defines the vertical travel of the mechanism as it tracks the film—this is the step in which sealing occurs. When our external event signals the end of the sealing process, we abort step I

and transition immediately to step II, during which the mechanism travels with the film for a short distance to allow the jaws to open. In step III the jaws return upward to their starting position. As in

the previous case, the final step is a “Flex Step,” meaning that the system automatically calculates a trajectory such that we return to our defined start position at a fixed master position. Figure 7 shows how the vertical motion changes as a function of the event timing. If the event does not occur, the default trajectory is followed.

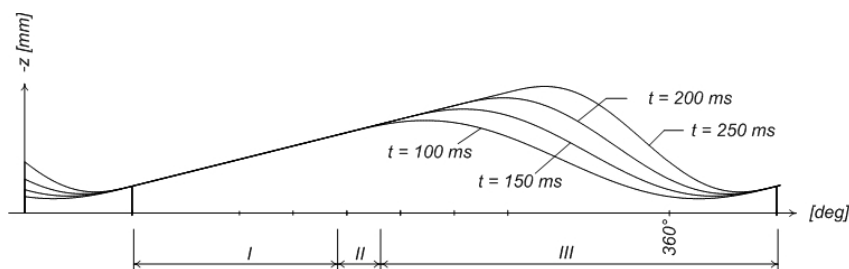

Figure 7. Family of curves defined by event-driven Flex Profile, z-axis. Sealing times of $t = 100$ ms, 150 ms, 200 ms and 250 ms (default) are shown.

Other features of Flex Profile

Key features of Flex Profile include the ability to combine synchronous and time-based steps in a single data structure, well-integrated event handling, and the so-called Flex Steps that are calculated in-process to adhere to a specified end-point constraint. Other features include:

- Support for most well-known motion laws, including poly5, poly7, modified sinusoid, modified trapezoid, etc.
- Easy inclusion of additional, user-defined motion laws
- Legacy support for tradition cam tables
- Well-integrated graphical editing/analysis tool
- Single-cycle or endless execution
- Automatic and configurable synchronization of the slave to the master.

Flex Profile is a control-side technology included as standard in all Rexroth MLC motion-logic controls. Flex Profiles, including their associated events, may be defined using the Rexroth

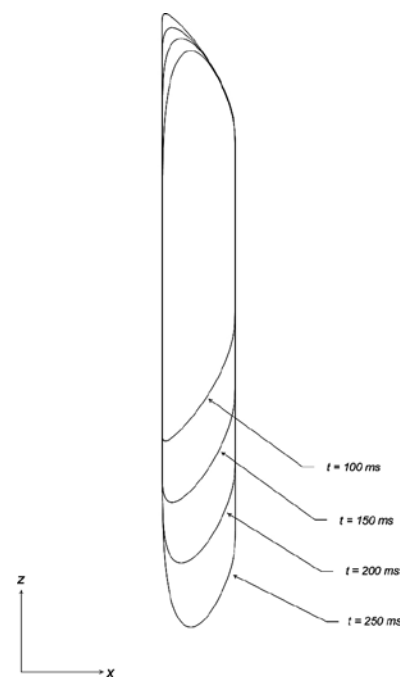

Figure 8. Sample of trajectories generated by Flex Profile as a function of the sealing time t . Note that the trajectory is calculated in-process and that the event which signals the end of sealing may occur at any time during the sealing process.

Cam Builder graphical interface or, in cases where end-user or recipe-driven input is required, programmatically.

Conclusion

Flex Profile is not the only solution for programming challenges. However, because of its broad, comprehensive approach, many situations—including many not previously thought of as “cam” situations—may be addressed using Flex Profile. This allows users to approach their programming tasks in an efficient, uniform manner. Such uniformity tends to make for simpler, more readable and comprehensible code.

By integrating event handling into the electronic cam model, Flex Profile offers a unique, comprehensive approach to many different motion demands. This, together with the ability to seamlessly combine synchronous and time-based steps into a single data structure, offers the potential to optimize system performance beyond what is possible using traditional approaches.

Rexroth
Bosch Group